

BELT CONVEYORS

BM 8411/8421

Straight

Center drive



24V

48V

400V

Product description

The belt conveyor is used for the transport of goods that are not suitable for roller tracks, and for all types of goods on inclines and declines. The belt conveyor is available with gear motor (BM 8411) or drum motor (BM 8421).

The design with gear motor (BM 8411) can also be used in the chill area.

Scope of delivery

- Supply incl. 1 sensor
- Module is completely assembled, maybe split into sections
- Please order supports and end caps separately



BELT CONVEYORS BM 8411/8421

Straight
Center drive

Technical data

General technical data	
Max. load capacity*	50 kg/m (standard)
Max. load capacity per module*	550 kg
Conveyor speed*	0.1 to 2.5 m/s
Incline/decline	Max. 18°
Ambient temperature	+5 to +40 °C (drum motor); -5 to +40 °C (gear motor)
Drive	
Rated voltage	400 V
Electrical power	Max. 3 kW
Motor type	Drum motor/gear motor
Materials	
Conveyor belt	Level: smooth, 2-layer, PVC; rising/falling gradient: grooved longitudinally, 2-layer, PVC
Slider bed	Zinc-plated sheet steel 2.5 mm; zinc-plated sheet steel 3 mm (from BF = 840 mm)

*The combination of maximum values is not always possible.

Dimensions

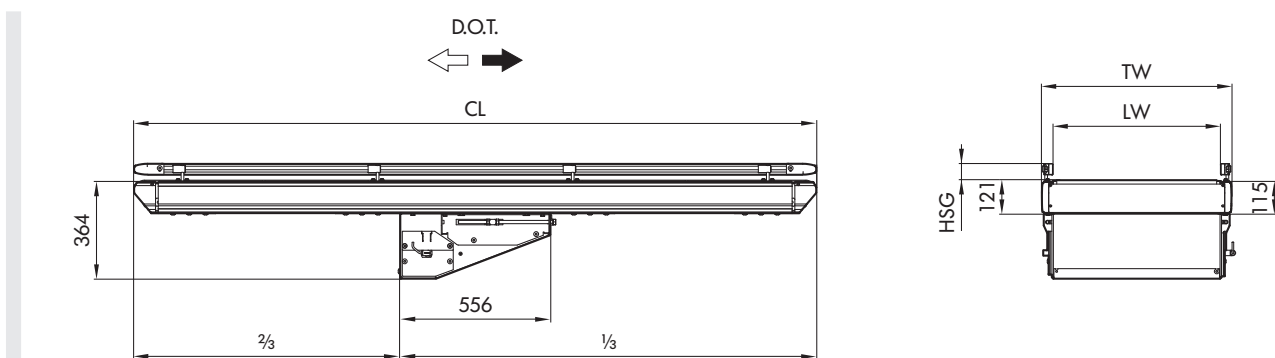

BF	Rated width	420, 620, 840 mm (others on request)
LW	Lane width	BF (+120/-90 mm per side with flexible side guide)
CL	Module length	1500 to 20010 mm
TW	Module width	BF + 80 mm
HSG	Side guide height	35 - 65 mm